

- NOTES: 1.) TUBE - BLACK OIL RESISTANT SYNTHETIC RUBBER
 2.) REINFORCEMENT - ONE BRAID OF HIGH TENSILE STEEL WIRE.
 3.) COVER - BLACK OIL ABRASION RESISTANT SYNTHETIC RUBBER.
 4.) WORKING P.S.I. - 2000, BURSTING P.S.I. - 8000
 5.) CAP BOTH ENDS.

DWG NO. 67576

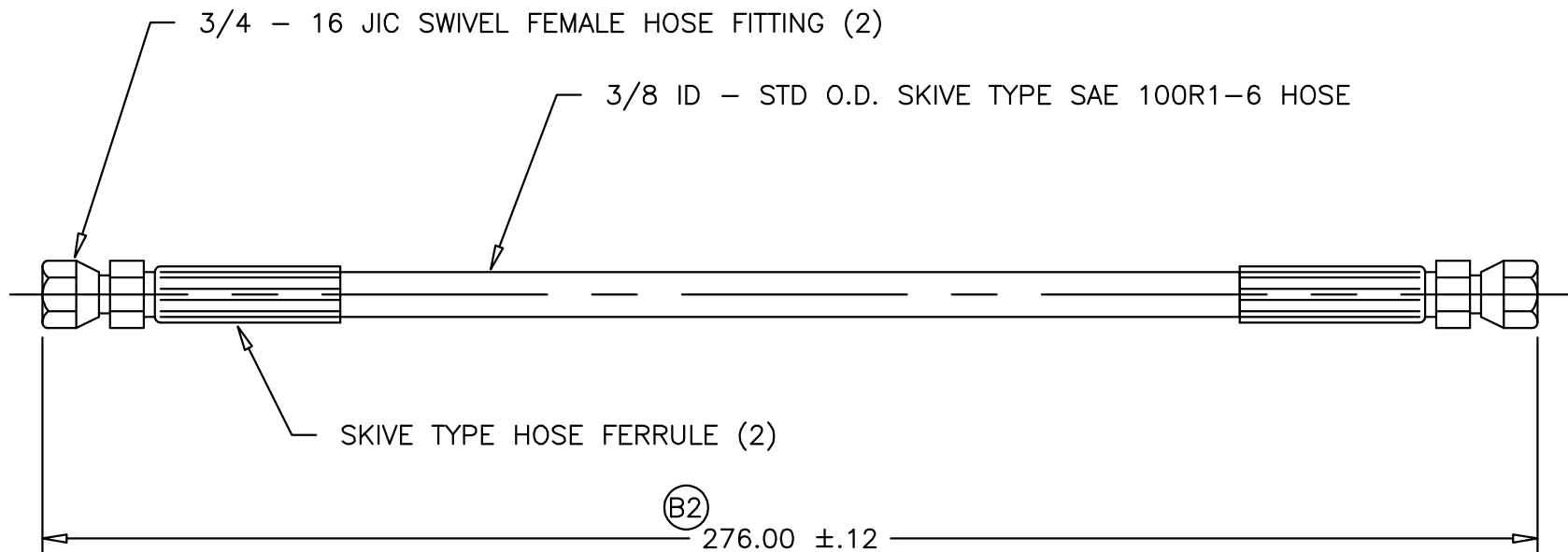

					MATERIAL	PPP		[STD MIL TOL UNLESS SPEC.]	
					TOLERANCE UNLESS SPECIFIED	WIL-RICH a division of TIC UNITED CORP.			
					DECIMAL: .X ±.06 [1,5] .XX ±.03 [0,8] .XXX ±.015 [0,38]				
049822	LM	5/98	B2	300±.12	HOLE DIA: -.005 +.015 [-0,13 +0,38]	HYD HOSE 3/8 x 276 FF R1 JIC/JIC (B1)			
049822	LM	5/98	B1	HYD HOSE 1/2X300 FF R1 JIC/JIC	ANGLES: ±1.5° METRIC: []				
049805	KEN	4/98	A	RELEASE	DO NOT SCALE THIS DRAWING				
EO	BY	DATE	LTR	REVISION	PREP KEN 4-15-98	CHK	APVD WJS	SCALE NONE	DWG NO. 67576

TSC — NOTICE: WIL-RICH a division of TIC UNITED CORP. claims proprietary rights to the information disclosed on this drawing. It is issued in confidence for engineering information only, and may not be reproduced or used to manufacture anything shown hereon without direct written permission from WIL-RICH a division of TIC UNITED CORP. to the user.