

NOTES:

Scale: 1.000				PART NO: 30001748	
ECO	BY	DATE	REV	REVISION DESCRIPTION	
12307	TLK	1-23	01	RELEASE	

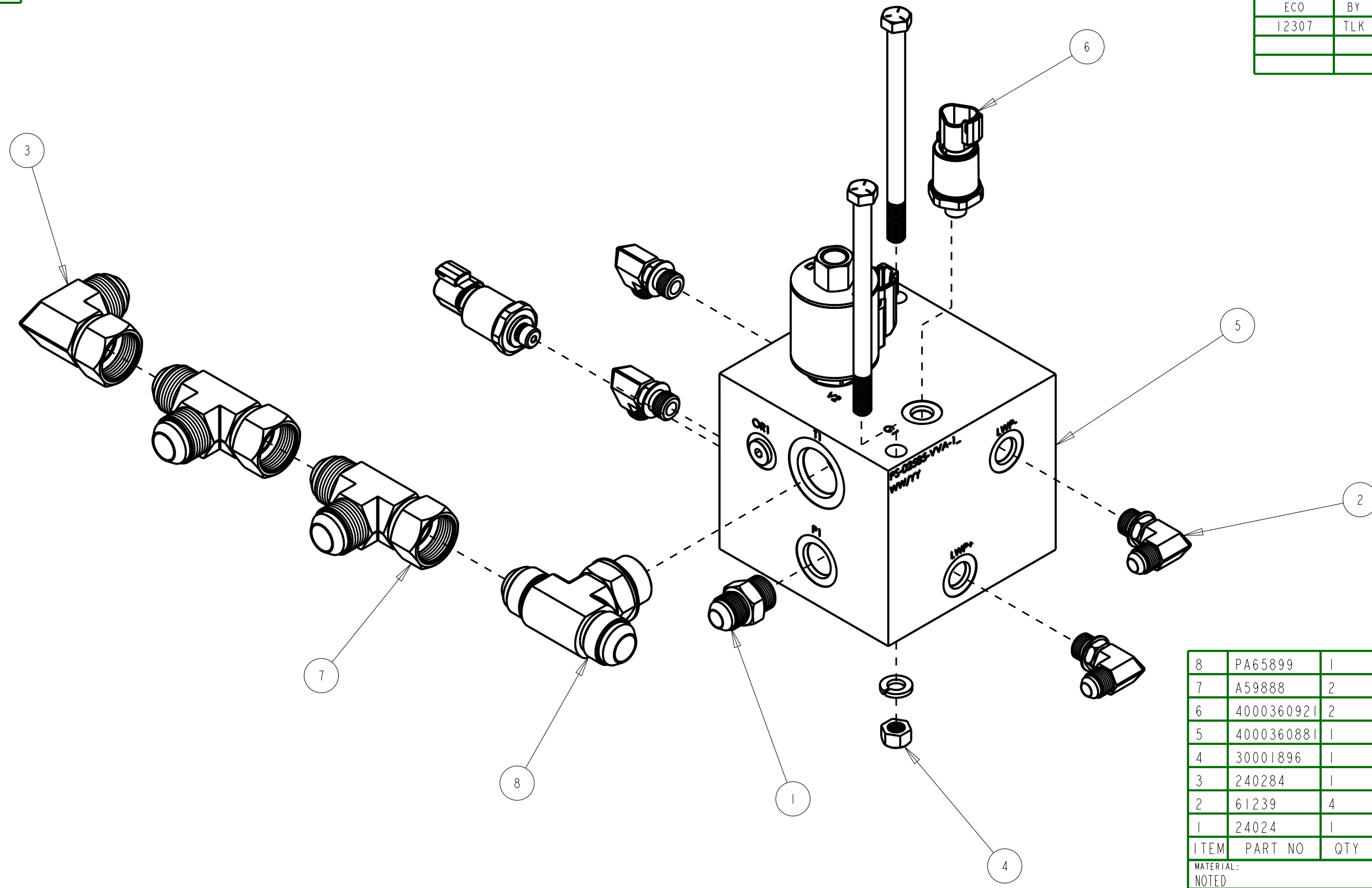

8	PA65899	1	FTG-TEE: 12MJ-12MJ-12MB
7	A59888	2	TEE 12MJ X 12FJ X 12MJ
6	4000360921	2	PRESSURE TRANSDUCER - ASHCROFT P/N- G27MEK42DT5000#G
5	4000360881	1	WEIGHT TRANSFER MANIFOLD - WINGS PS-02585-VVA-10
4	30001896	1	HK-HYD BLK WEIGHT TRANSFER
3	240284	1	ELB 12MJ X 12FJX
2	61239	4	ELB 6MORB X 6MJ
1	24024	1	ADP 8MORB X 8MJ

ITEM	PART NO	QTY	DESCRIPTION
MATERIAL:			FINISH:
NOTED			N/A
MATERIAL NO:			MATERIAL REQ:

DO NOT SCALE THIS DRAWING REMOVE ALL SHARP EDGES		<b>VÄDERSTAD INC.</b>	
Engineer:	TLK	NOTICE: THIS DOCUMENT CONTAINS PROPRIETARY INFORMATION AND IT SHALL NOT BE USED OR REPRODUCED OR IT'S CONTENTS DISCLOSED IN WHOLE OR IN PART, WITHOUT PRIOR WRITTEN CONSENT OF VÄDERSTAD	
DATE:	8-9-23	DESCRIPTION:	
ITEM CLASS:	091	HYDRAULIC BLOCK ASSEMBLY-WEIGHT TRANSFER	
WEIGHT (LB):	18.756	SHEET NO:	PART NO:
		1 OF 1	30001748
			REV: 1

TOLERANCE UNLESS SPECIFIED	
DECIMALS	INCH
0.1	±.06
0.01	±.03
0.001	±.015
HOLE DIA:	-.005 / +.015
ANGLES:	±1.0°
THIRD ANGLE PROJECTION	